



## Studies on the oxygen potentials of $(U_yTh_{1-y})O_{2+x}$ solid solutions

S. Anthonysamy, K. Nagarajan, P.R. Vasudeva Rao \*

*Fuel Chemistry Division, Chemical Group, Indira Gandhi Centre for Atomic Research, Tamil Nadu, Kalpakkam 603 102, India*

### Abstract

The oxygen potentials of  $(U_yTh_{1-y})O_{2+x}$  solid solutions ( $y$  varying from 0.54 to 0.9) were measured by using a gas equilibration method, employing  $H_2 + H_2O$ ,  $CO + CO_2$  and  $CO_2 + H_2$  gas mixtures. The measurements covered an oxygen potential range of  $-450$  to  $-220$   $\text{kJ mol}^{-1}$  and the O/M ratios varied between 2.000 and 2.035. The attainment of equilibrium as well as the actual oxygen potentials realised in the gas mixture were determined by using an oxygen probe based on calcia stabilized zirconia solid electrolyte. The results of the measurements indicate that the oxygen potentials of  $(U_yTh_{1-y})O_{2+x}$  solid solutions are a function of both the uranium valence and the U/(U + Th) ratio. Partial molar enthalpies and entropies of solution of oxygen in the solid solutions were also computed from the temperature dependance of the oxygen potentials. © 1997 Elsevier Science B.V.

### 1. Introduction

$(U, Th)O_2$  solid solutions are being developed as fuels for thermal breeder reactors and also for high temperature gas cooled reactors. India has vast reserves of thorium and hence utilization of thorium can reduce uranium consumption and diversify the nuclear energy resources for a long term nuclear energy programme. In order to understand and predict the fuel behaviour during irradiation, the thermodynamic properties of  $(U, Th)O_2$  solid solutions must be well known. The oxygen potential of an oxide fuel material plays a key role in determining the mechanism of fuel-clad chemical interaction. Several investigators [1–7] have measured the oxygen potentials of  $(U_yTh_{1-y})O_{2+x}$  solid solutions. The temperature ranges and the compositions over which oxygen potentials had been measured by these investigators are given in Table 1. The results of different investigators for the overlapping compositions and temperatures are found to be in disagreement with one another. For example, as observed by Matsui et al. [1], the oxygen potential values of  $(U_{0.2}Th_{0.8})O_{2.02}$  range between  $-300$  and  $-220$   $\text{kJ mol}^{-1}$  at 1273 K. Disagreement also

exists as to whether the oxygen potentials of  $(U, Th)O_2$  solid solutions are a function only of the uranium valence or a function of both uranium valence as well as the U/(U + Th) ratio [1,3,8]. The values of the partial molar enthalpies and entropies of solution of oxygen for the mixed oxides, derived from the temperature variation of the oxygen potentials also differ significantly [1]. Among all the earlier investigators, only Aronson and Clayton [2] have studied the solid solutions with  $y \geq 0.5$  (1250 K). Hence in the present study, the oxygen potentials of  $(U_yTh_{1-y})O_{2+x}$  solid solutions with  $y$  ranging from 0.54 to 0.90 were measured at 1073 and 1173 K, with a view to

Table 1

The temperature ranges and the compositions of  $(U, Th)O_2$  solid solutions for which oxygen potential data are available in the literature

Investigators	$y$ in $(U_yTh_{1-y})O_{2+x}$	Temperature range (K)
J.S. Anderson et al. [6]	0.03, 0.063, 0.244	1003–1203
L.E.J. Roberts et al. [7]	0.05–0.06	1123
Aronson and Clayton [2]	0.3–0.9	1250
S. Tanaka et al. [3]	0.05–0.3	1250
M. Ugajin [4,5]	0.05–0.2	1273–1473
T. Matsui et al. [1]	0.2–0.4	1282–1373

\* Corresponding author. Tel.: +91-4114 40 229/40 398; fax: +91-4114 40 365/40 396; e-mail: vasu@igcar.ernet.in.

elucidating the behaviour of uranium rich solid solutions which in turn will help to understand the U–Th–O system completely.

## 2. Experimental

### 2.1. Oxide samples

The mixed oxide samples containing 54, 77 and 90 mol%  $\text{UO}_2$  were prepared as follows: Ammonium diuranate and thorium hydroxide were coprecipitated from a mixture of uranium and thorium nitrate solutions. The precipitates were then dried and calcined at 973 K for 5 h. The calcined powders were compacted at 500 MPa into 10 mm diameter pellets and sintered at 1673 K for 5 h in a flowing hydrogen stream. The formation of the solid solutions was confirmed from the linear relationship between the compositions and the lattice parameters obtained by X-ray diffraction analysis. The U and Th contents of the solid solutions were determined by using a complexometric titration [9,10]. About 200 mg of the oxides were dissolved in concentrated  $\text{HNO}_3$  with a few drops of diluted HF. 1 ml aliquots of this solution were titrated against diethylenetriaminepentaacetic acid using xylenol orange as the indicator to determine the amount of thorium [9]. Then to the same aliquot, acetic acid buffer was added to adjust the pH to 3–4. The uranium content was then determined by titrating against pyridene 2,6 dicarboxylic acid using arsenazo-1 as indicator [10].

### 2.2. Experimental assembly and procedure

A schematic diagram of the experimental assembly is shown in Fig. 1. Essentially, it consisted of a gas mixing set up and an oxygen probe based on calcia stabilised zirconia solid electrolyte with Sn/ $\text{SnO}_2$  or In/ $\text{In}_2\text{O}_3$  as the reference electrode. In the gas mixing part of the set up, pure  $\text{H}_2$ , pre-mixed Ar + 5% $\text{H}_2$  or Ar + 1% $\text{H}_2$  gases

were passed through a water bath maintained at 303 K.  $\text{CO}_2$  +  $\text{H}_2$  gas mixture was employed for measurements at higher oxygen potentials. The oxygen potentials of the gas mixtures were adjusted by varying the flow rates of the two gases by using mass flow controllers. In some cases,  $\text{CO}_2$  gas passed through a tower containing copper metal granules at a constant temperature was also employed. The oxygen potential of the resultant gas mixture ( $\text{CO}_2$  + CO) was adjusted by varying the temperature of the tower containing copper metal granules.

In a typical equilibration experiment, the gas mixture having a known oxygen potential was passed over the mixed oxide sample kept at the bottom of the alumina tube housing the oxygen probe so that the probe and the sample were at the constant temperature zone of a resistant wire wound furnace. The probe was positioned above the sample such that it was always measuring the oxygen potential of the gas in equilibrium with the sample. The temperature of the furnace was controlled within  $\pm 2$  K by using a proportional integral derivative temperature controller. The attainment of equilibrium as well as the actual oxygen potential realised in the gas mixture were determined by using the oxygen probe. The freshly prepared (U, Th) $\text{O}_2$  mixed oxide pellets were equilibrated to an oxygen potential of  $-450$  kJ mol $^{-1}$ . These samples were assumed to have attained a reference state of O/M = 2.000, because mixed oxide samples that were earlier reduced in pure hydrogen at 1673 K for 5 h showed no weight change when equilibrated with a gas mixture whose oxygen potential was  $-450$  kJ mol $^{-1}$ . The samples were then equilibrated to various oxygen potentials in the range of  $-380$  to  $-220$  kJ mol $^{-1}$ . The time of equilibration varied between 6 to 42 h depending on the temperature, composition of the sample and the final O/M value. The O/M values of the equilibrated samples were calculated from the weight gain with respect to the reference state.

The uncertainty in the experimental values of the oxygen potentials has been estimated to be  $\pm 2$  kJ mol $^{-1}$ . Uncertainties in the measurements of EMF and tempera-

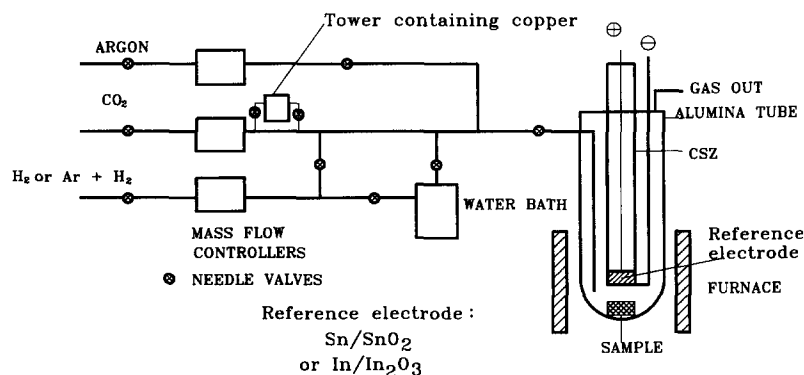

Fig. 1. Schematic diagram of the experimental assembly.

ture are the main factors responsible for the errors. The uncertainty in the O/M value has been estimated to be  $\pm 0.001$ .

### 3. Experimental results and discussion

Oxygen potentials of  $(U_yTh_{1-y})O_{2+x}$  solid solutions with  $y = 0.54, 0.77$  and  $0.9$  measured at  $1073$  and  $1173$  K in the present study are shown in Fig. 2 along with other results reported in the literature [1,2,5]. Since the numerical values of the oxygen potentials of  $(U_yTh_{1-y})O_{2+x}$  ( $y = 0.2$  and  $0.4$ ) measured by Matsui et al. [1] were not available, only a few of their results (from the plots in their paper) on the solid solution with  $y = 0.4$  at  $1473$  K have been included in Fig. 2 for the purpose of comparison. Direct comparison of our results for  $y \geq 0.5$  with most of the other results reported in the literature is not possible, since they cover only thorium rich compositions ( $y \leq 0.5$ ). The only literature data which can be compared with our results is that of Aronson and Clayton [2]. As is shown in Fig. 2 our results at  $1173$  K for  $y = 0.9$  and  $x = 0.0345$  are found to be more negative ( $\sim 36$  kJ mol $^{-1}$ ) than those of Aronson and Clayton for  $y = 0.9$  and  $x = 0.042$  at  $1250$  K. However, it is to be noted that the temperatures of the two sets of measurements differ by about  $80$  K and also the O/M ratios are different. It is also found from our measurements that there is a systematic increase in the oxygen potential with decreasing uranium content at a given uranium valence and temperature, or with increasing temperature at a given uranium valence and uranium content, in accordance with the results reported in the literature [1–7].

A plot of the oxygen potentials of  $(U_yTh_{1-y})O_{2+x}$  measured in this study at  $1073$  K against mean uranium valence,  $V_U$ , ( $V_U = 4 + 2x/y$ ) is shown in Fig. 3. Wood-

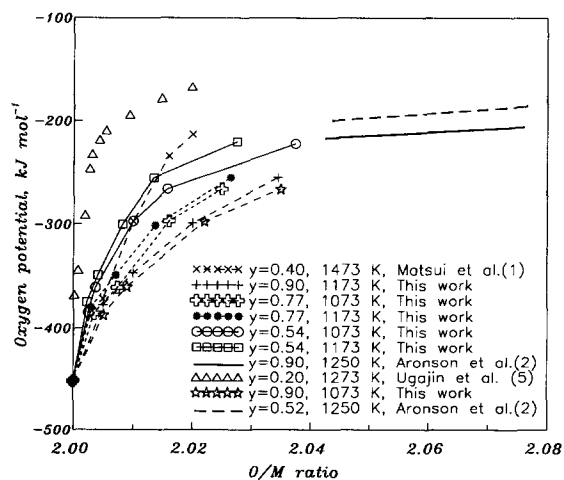

Fig. 2. The oxygen potentials of  $(U_yTh_{1-y})O_{2+x}$  solid solutions.

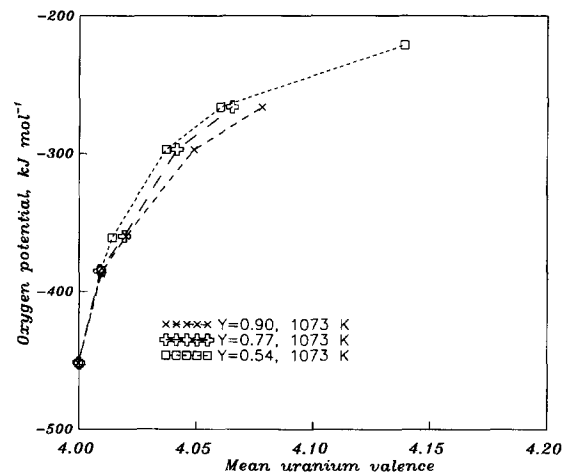

Fig. 3. Variation of oxygen potentials of  $(U_yTh_{1-y})O_{2+x}$  solid solutions with mean uranium valence.

ley and Adamson [8] and Tanaka [3] have suggested that the oxygen potentials of  $(U_yTh_{1-y})O_{2+x}$  are a function of only uranium valence and independent of the U/(U + Th) ratio. Aronson and Clayton [2] also indicated that the oxygen potentials are approximately the same for equal values of  $x$  in the range of  $y$  from  $0.7$  to  $1.0$ . However, from our results (Fig. 3) it is seen that the oxygen potentials of  $(U_yTh_{1-y})O_{2+x}$  solid solutions with  $y \geq 0.5$  are a function of both the uranium valence and the U/(U + Th) ratio. The results for  $1173$  K also follow the same trend. Our results are in accordance with the results reported by Matsui et al. [1] for the solid solutions with  $y \leq 0.3$  at temperatures above  $1282$  K and by Ugajin [4] for the solid solutions with  $y = 0.05, 0.1$  and  $0.2$  at temperatures between  $1273$  and  $1473$  K.

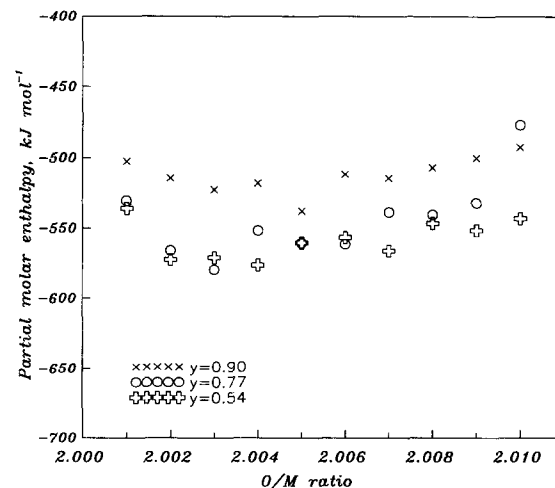

Fig. 4. Partial molar enthalpies of oxygen in  $(U_yTh_{1-y})O_{2+x}$ .

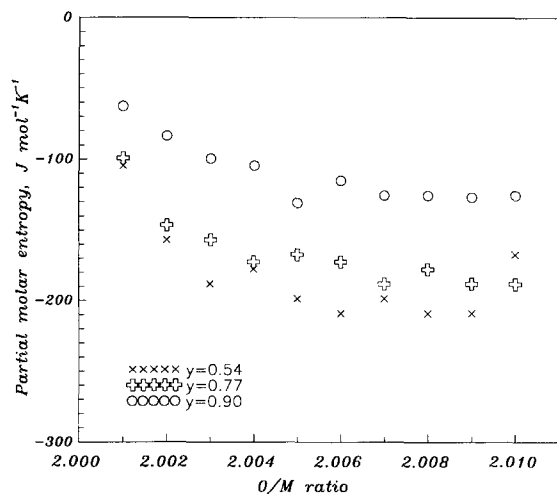

Fig. 5. Partial molar entropies of oxygen in  $(U_yTh_{1-y})O_{2+x}$ .

The partial molar enthalpies and entropies of oxygen for  $(U_yTh_{1-y})O_{2+x}$  computed from the oxygen potentials measured in this study are shown in Figs. 4 and 5, respectively. The results for the solid solutions with  $y \geq 0.5$  and  $x \leq 0.01$  are reported in this study for the first time. The partial molar enthalpies reported by Aronson and Clayton [2] for the solid solutions with  $y = 0.9, 0.71$  and  $0.52$  and  $x \geq 0.04$  are found to be less negative compared to the present partial molar enthalpy values for  $y = 0.9, 0.77$  and  $0.54$  and  $x \leq 0.01$ . However, the two sets of data on the partial molar entropies of oxygen are found to be in the range of  $-100$  to  $-200$   $J K^{-1} mol^{-1}$ . The partial molar enthalpies and entropies of oxygen for the ternary solid solutions  $(U, M)O_{2+x}$  where  $M = La, Eu, Gd, Y, Zr, Mg$ , have been found to increase negatively with increasing  $M$  content or excess oxygen and exhibit a peak around  $O/M = 2.000$  by the other investigators [11–17]. Matsui et al. [1] have indicated that the values of partial molar enthalpies and entropies for  $(U_{0.4}Th_{0.6})O_{2+x}$  showed a maximum at  $O/M \cong 2.001$ , although a clear maximum was not observed by both Matsui et al. [1] and Ugajin [5] for  $(U_{0.2}Th_{0.8})O_{2+x}$ . The present study indicates that the values of the partial molar entropies for  $(U_yTh_{1-y})O_{2+x}$  solid solutions with  $y \geq 0.5$  increase negatively with increasing oxygen content and thorium content. However, the decrease in the partial molar enthalpy values with increasing oxygen or thorium content is not significant. The trivalent ions such as  $Gd, Y, La$  etc have a more pronounced effect on the partial molar quantities than the tetravalent  $Th$ . For example, the change in the values of the partial molar entropy due to the addition of 1 mol% of  $Gd$  is about  $-4.2$   $J mol^{-1} K^{-1}$  [14], whereas addition of 10 mol% of  $Th$  causes only a change of about  $-9$   $J mol^{-1} K^{-1}$ . Fujino et al. [17] also indicated that the effect of  $Mg$  content on the partial molar quantities is greater in  $(U_yMg_{1-y})O_{2+x}$  than in  $(U_yTh_{1-y})O_{2+x}$ .

#### 4. Conclusion

The oxygen potentials of  $(U_yTh_{1-y})O_{2+x}$  solid solutions ( $y$  varying from 0.54 to 0.9) in the oxygen potential range  $-450$  to  $-220$   $kJ mol^{-1}$  and  $2.000 \leq O/M \leq 2.035$  at 1073 and 1173 K were measured for the first time to supplement the data already existing in the literature for  $(U, Th)O_2$  solid solutions of other compositions. It was observed that for a given  $O/M$  ratio, there is a systematic increase in the oxygen potential values with increasing thorium content. The results of the present measurements confirm that the oxygen potentials of  $(U_yTh_{1-y})O_{2+x}$  solid solutions are a function of both the uranium valence and the  $U/(U + Th)$  ratio. The partial molar enthalpies and entropies of oxygen for  $(U_yTh_{1-y})O_{2+x}$  solid solutions with  $y \geq 0.5$  and  $x \leq 0.01$  are reported in this study for the first time.

#### Acknowledgements

The authors are grateful to K.V.G. Kutty and N.L. Sreenivasan for their help in the characterisation of the samples by X-ray diffraction and chemical methods, respectively.

#### References

- [1] T. Matsui, K. Naito, *J. Nucl. Mater.* 132 (1985) 212.
- [2] S. Aronson, J.C. Clayton, *J. Chem. Phys.* 32 (1960) 749.
- [3] S. Tanaka, E. Kimura, A. Yamaguchi, J. Moriyama, *J. Jpn. Inst. Met.* 36 (1972) 633.
- [4] M. Ugajin, *J. Nucl. Mater.* 110 (1982) 140.
- [5] M. Ugajin, T. Shiratori, H. Shiba, *J. Nucl. Mater.* 116 (1983) 172.
- [6] J.S. Anderson, D.N. Edgington, L.E.J. Roberts, E. Wait, *J. Chem. Soc.* (1954) 3324.
- [7] L.E.J. Roberts, L.E. Russel, A.G. Adwick, A.J. Walter, M.H. Rand, P/26 UK Geneva Conference of Peaceful Uses of Atomic Energy, Vol. 28, 1958, p. 215.
- [8] R.E. Woodley, M.G. Adamson, *Thermodynamics of Nuclear Materials 1979*, Vol. 1 (IAEA, Vienna, 1980) p. 333.
- [9] E. Celon, S. Degetto, G. Marangoni, L. Baracco, *Talanta* 26 (1979) 160.
- [10] R. Pribil, V. Vaseley, *Talanta* 10 (1963) 899.
- [11] T. Matsui, K. Naito, *J. Nucl. Mater.* 138 (1986) 19.
- [12] E. Stadlbauer, U. Wichmann, U. Lott, C. Keller, *J. Solid State Chem.* 10 (1974) 341.
- [13] T. Fujino, K. Ouchi, Y. Mozumi, R. Ueda, H. Tagawa, *J. Nucl. Mater.* 174 (1990) 92.
- [14] K. Une, M. Oguma, *J. Nucl. Mater.* 110 (1982) 215.
- [15] K. Hagemark, M. Broli, *J. Am. Ceram. Soc.* 50 (1967) 563.
- [16] S. Aronson, J.C. Clayton, *J. Chem. Phys.* 35 (1961) 1055.
- [17] T. Fujino, J. Tateno, H. Tagawa, *J. Solid State Chem.* 24 (1978) 11.